

**CURRENT LOOP SUPPLY**  
(linearizing; field- and PC-configurable)

MODEL **M3LDY**

**BEFORE USE ....**

Thank you for choosing M-System. Before use, check the package you received as below.

If you have any problems or questions with the product, please contact M-System's Sales Office or representatives.

■ **PACKAGE INCLUDES:**

- Signal conditioner ..... (1)
- I/O range and tag name label sheet ..... (1)

■ **MODEL NO.**

Check that the model No. described on the specification label is exactly what you ordered.

■ **INSTRUCTION MANUAL**

This manual describes the necessary points of caution when you use this product, including installation, connection and basic maintenance procedures.

The M3LDY with Option /A is programmable using the PC configurator software. For detailed information on the PC configuration, refer to the M3CON instruction manual. The M3CON PC Configurator Software is downloadable at M-System's web site: <http://www.m-system.co.jp>.

**POINTS OF CAUTION**

■ **CONFORMITY WITH UL**

(UL is unavailable for certain model suffix options.)

- This equipment is suitable for use in a Pollution Degree 2 environment.
- This equipment is to be used with the maximum operating voltage 30Vrms and 42.4Vpeak or 60V DC.
- The equipment must be mounted inside a suitable fire enclosure.
- Operating temperature: -25 to +55°C (-13 to +131°F)

■ **POWER INPUT RATING & OPERATIONAL RANGE**

• Check the power rating for the unit on the specification label.

Rating 24V DC: 24V ±10%, approx. 3W

• Power fuse: A power fuse of the rating as shown below is incorporated for safety. However, DO NOT replace it by the user.

T 0.25A 125V

■ **SAFETY PRECAUTION**

• Before you remove the unit or mount it, turn off the power supply and input signal for safety.

■ **ENVIRONMENT**

- Indoor use
- When heavy dust or metal particles are present in the air, install the unit inside proper housing with sufficient ventilation.
- Do not install the unit where it is subjected to continuous vibration. Do not subject the unit to physical impact.
- Environmental temperature must be within -25 to +65°C (-13 to +149°F) with relative humidity within 0 to 95% RH in order to ensure adequate life span and operation.

■ **WIRING**

- Do not install cables (power supply, input and output) close to noise sources (relay drive cable, high frequency line, etc.).
- Do not bind the unit's cables together with cables where high noise levels are present. Do not install them in the same duct.

■ **AND ....**

- The unit is designed to function as soon as power is supplied, however, a warm up for 10 minutes is required for satisfying complete performance described in the data sheet.

**COMPONENT IDENTIFICATION**

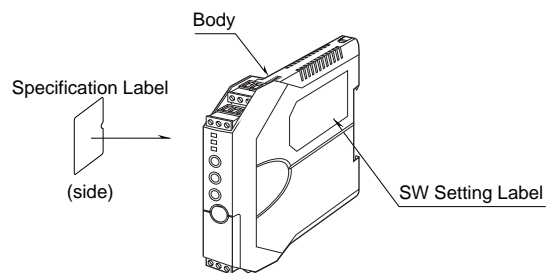

■ **HOW TO OPEN THE COVER WHEN SETTING DIP SW**

Hold at the top and bottom of the open unit as shown below and slide the housing cover gently to open until it hits the latching inside the unit.

**Caution:**

Handle the cover carefully to protect internal components from damage. DO NOT pull beyond where the housing cover is latched. The plastic housing may be damaged.

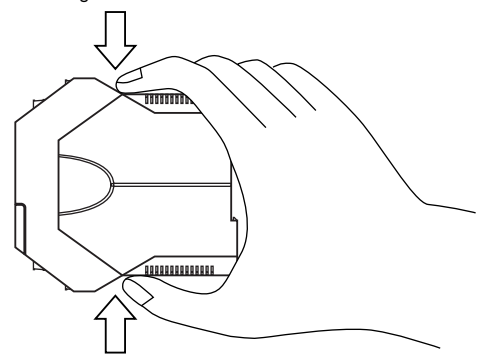

• **Housing Cover Fully Opened**

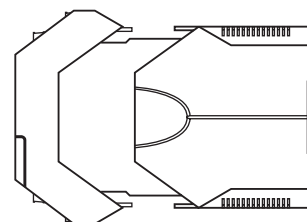

**HOW TO SEPARATE THE TERMINAL BLOCKS**

When you need to separate the terminal blocks from the transmitter body for wiring, insert a minus driver between the terminal block and the housing body, pull up the driver and pull out the terminal block.

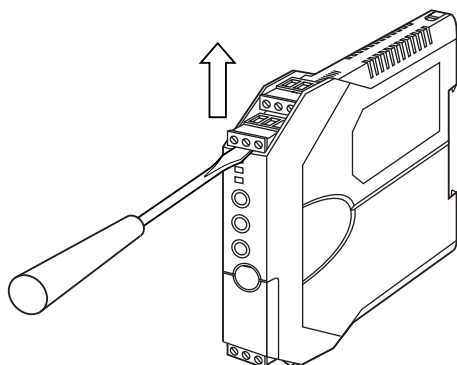

**INSTALLATION**

**DIN RAIL MOUNTING**

Set the unit so that its DIN rail adaptor is at the bottom. Position the upper hook at the rear side of the unit on the DIN rail and push in the lower. When removing the unit, push down the DIN rail adaptor utilizing a minus screwdriver and pull.

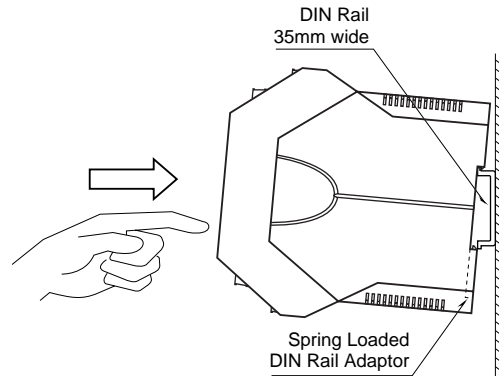

**TERMINAL CONNECTIONS**

Connect the unit by referring to the diagram below.

**EXTERNAL DIMENSIONS mm (inch)**

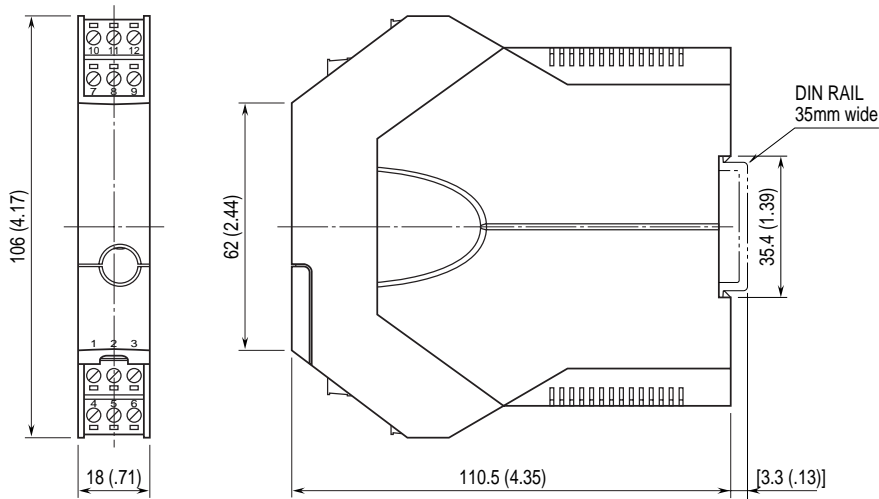

⚠When mounting, no extra space is needed between units.

**CONNECTION DIAGRAM**

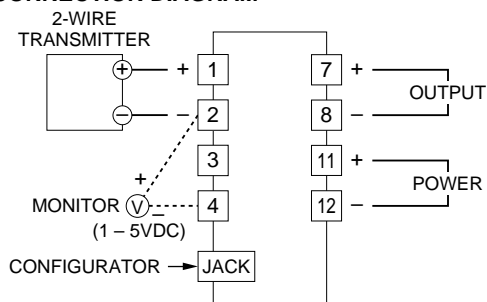

**When Used as Isolator**

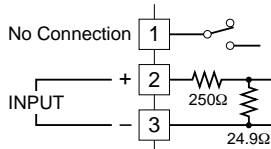

## EXTERNAL & INTERNAL VIEWS

### FRONT VIEW

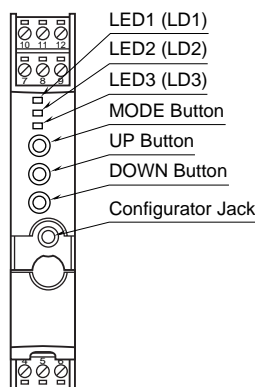

### SIDE VIEW

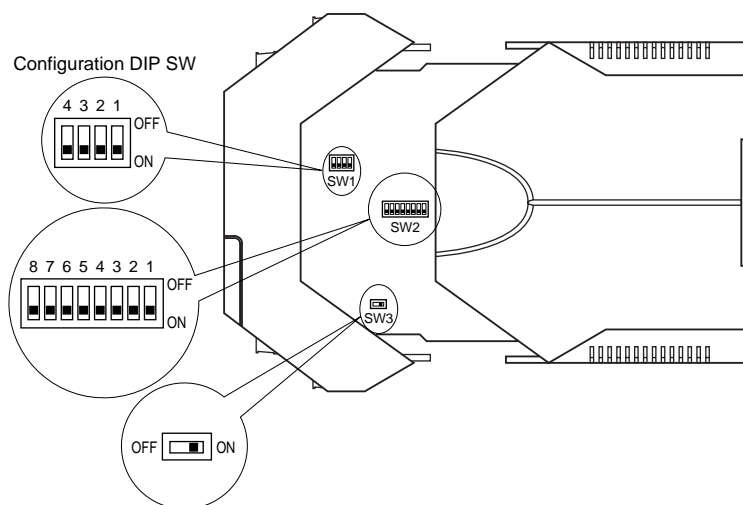

## CONFIGURATION MODE & DIP SW SETTINGS

When you program the transmitter module, two configuration modes are available: Field Configuration using DIP SW / control buttons, and PC Software. (The Option B type is for the field configuration only.)

The internal DIP switches are used to configure input and output type. Once the module is configured, precise ranges are set up with the front control buttons using a simulator connected to the input terminals and a multimeter connected to the output terminals as a reference.

The calibrated input and output ranges are stored in the internal memory. The module reads the DIP-switch-calibrated configuration only once after the power supply is turned on. Set the switches with the power supply removed. Selectable I/O type and ranges are listed in Table 5 and 6.

### DIP SW CONFIGURATION MODE

Turn the SW2-8 OFF to enable the DIP SW (Field Configuration) mode as shown in Table 1. See Table 2 to configure the input and Table 3 for the output.

### PC CONFIGURATION MODE

Turn the SW2-8 ON to enable the PC Configuration mode as shown in Table 1. All programmable features can be set up on a PC regardless of other DIP SW setting except that the output type must be selected with the DIP SW1-1 through SW1-4 (See Table 4).

For detailed information on the PC configuration, refer to the M3CON instruction manual.

### CONFIGURATION MODE (SW2)

Table 1

MODE	SW2-8	
DIP SW	OFF	Configuration mode can be confirmed with the front LED.
PC	ON	

### INPUT TYPE (SW2 & 3)

Table 2

INPUT TYPE	SW2-7	SW3
DC current (isolator use)	ON	OFF
2-wire loop (DC supply use)	OFF	ON

### OUTPUT TYPE (SW2 & 1)

Table 3

OUTPUT	SW2-4	SW2-3	SW1-4	SW1-3	SW1-2	SW1-1
0 – 20mA	OFF	OFF	OFF	ON	OFF	OFF
-2.5 – +2.5V	OFF	ON	ON	OFF	OFF	ON
-10 – +10V	ON	OFF	ON	OFF	ON	OFF

### OUTPUT TYPE / PC CONFIG (SW1)

Table 4

OUTPUT	SW1-4	SW1-3	SW1-2	SW1-1
0 – 20mA	OFF	ON	OFF	OFF
-2.5 – +2.5V	ON	OFF	OFF	ON
-10 – +10V	ON	OFF	ON	OFF

### INPUT TYPE & RANGE

Table 5

INPUT TYPE	MINIMUM SPAN	MAXIMUM RANGE
DC Current	2mA	0 to 20mA

### OUTPUT TYPE & RANGE

Table 6

OUTPUT TYPE	MINIMUM SPAN	MAXIMUM RANGE	CONFORMANCE RANGE
DC Current	1mA	0 to 20mA	0 to 24mA
DC Voltage, Narrow Spans	250mV	-2.5 to +2.5V	-3 to +3V
DC Voltage, Wide Spans	1V	-10 to +10V	-11.5 to +11.5V

## CHECKING

- 1) Terminal wiring: Check that all cables are correctly connected according to the connection diagram.
- 2) DIP SW setting: Check that the switches are set to appropriate positions.
- 3) Power input voltage: Check voltage across the terminal 11 – 12 with a multimeter.
- 4) Input: Check that the input signal is within 0 – 100% of full-scale.
- 5) Output: Check that the load resistance meets the described specifications.

## I/O RANGING & FINE ADJUSTMENTS

After the DIP SW setting is complete, set up the precise input and output range using the front control buttons. The front LEDs' colors and flashing patterns help you to easily identify the transmitter's status and confirm the setup actions in each step of Calibration Modes. Please read the following explanations referring to "Calibration Flow Chart" below.

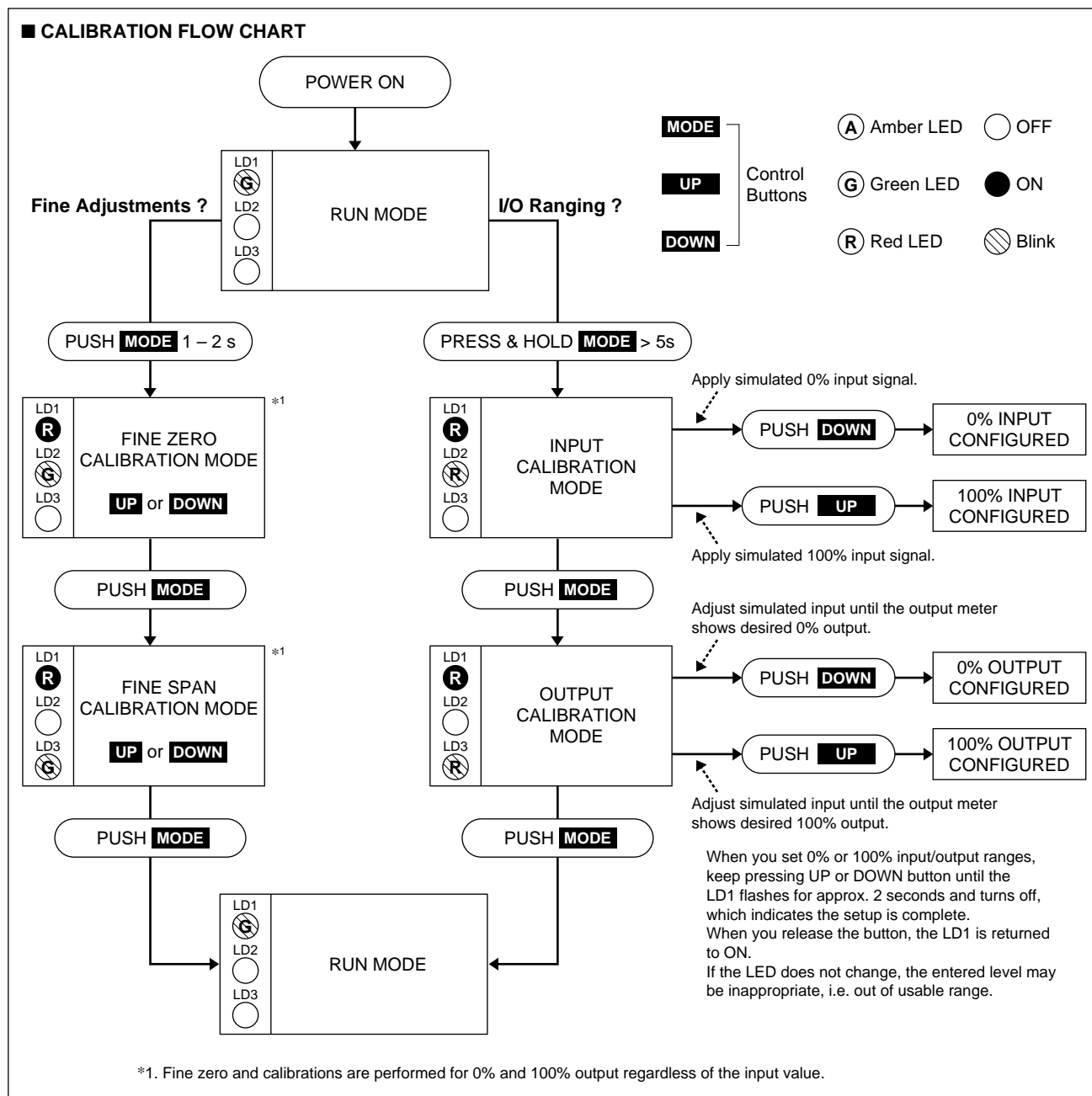

### ■ PREPARATION (e.g. M3LDY-R/A)

- 1) Mount the DIP-SW-configured M3LDY on to a DIN rail.
- 2) Connect the M3LDY to a simulator and a multimeter and to a DC power source as shown to the right.
- 3) Turn the power supply on and wait for 10 minutes.

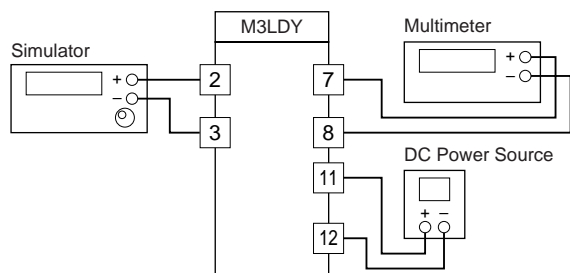

### ■ INPUT & OUTPUT RANGING

[Example]

Setting input to 4 – 20mA DC and output to 1 – 5V DC

- 1) Run Mode: Confirm that the LD1 green light is blinking.
- 2) Input Configuration Mode: Press MODE button for longer than 5 seconds until the LD1 red light is ON and the LD2 red light is blinking.
- 3) 0% Input Ranging: Apply the desired minimum input level (e.g. 4mA) from the simulator and push DOWN button until the LD1 flashes for approx. 2 sec. and then turns OFF. When you release the button, the LD1 is returned to ON.  
The flashing LD1 means that the value is stored in the memory. If the LED does not change, the entered level may be inappropriate: too small a span, or out of usable range (same for all steps).
- 4) 100% Input Ranging: Apply the desired maximum input level (e.g. 20mA) from the simulator and push UP button until the LD1 flashes for approx. 2 sec. and then turns OFF. When you release the button, the LD1 is returned to ON.
- 5) Output Configuration Mode: Push MODE button and confirm that the LD3 red light instead of LD2 is blinking.
- 6) 0% Output Ranging: Increase or decrease the simulated input until the meter shows the desired minimum output level (e.g. 1V). Push DOWN button until the LD1 flashes for approx. 2 sec. and then turns OFF. When you release the button, the LD1 is returned to ON.
- 7) 100% Output Ranging: Increase or decrease the simulated input until the meter shows the desired maximum output level (e.g. 5V). Push UP button until the LD1 flashes for approx. 2 sec. and then turns OFF. When you release the button, the LD1 is returned to ON.
- 8) Run Mode: Programming complete, push MODE button and confirm that only the LD1 green light is blinking.

### ■ ZERO & SPAN ADJUSTMENTS

After the transmitter is installed and operational, fine zero and span tuning can be performed as explained below. Both zero and span are adjustable within  $\pm 15\%$ .

- 1) Run Mode: Confirm that the LD1 green light is blinking.
- 2) Fine Zero Calibration Mode: Press MODE button for 1 or 2 seconds until the LD1 red light is ON and the LD2 green light is blinking.
- 3) Use UP (increase) and DOWN (decrease) buttons to adjust the output to 0%.

- 4) Fine Span Calibration Mode: Push MODE button and confirm that the LD3 green light instead of LD2 is blinking.
- 5) Use UP (increase) and DOWN (decrease) buttons to adjust the output to 100%.
- 6) Run Mode: Push MODE button and confirm that only the LD1 green light is blinking.

Note 1: Calibration steps can be skipped when not needed by repeating pushing MODE buttons.

Note 2: There is no stated order of setting 0% and 100% levels or no limitation of entering values for multiple times within one step of Calibration Mode. Signal level is stored each time the respective UP or DOWN button is pressed.

### ■ I/O RANGE LABEL

Blank I/O range labels are included in the product package. Write in the configured ranges and put the label on the side above the specification label as shown below.

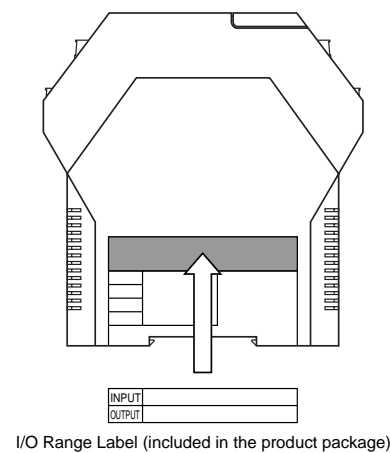

## STATUS INDICATOR LED

Combinations of the three front LEDs (LD1, LD2, LD3) indicate the transmitter's operating status by different flashing patterns.

Examples are shown below.

- A Amber LED      OFF  
G Green LED      ON  
R Red LED      Blink

NORMAL OPERATION (RUN) MODE	
LD1 <span style="border: 1px solid black; border-radius: 50%; padding: 2px;">G</span> LD2 <span style="border: 1px solid black; border-radius: 50%; padding: 2px;"> </span> LD3 <span style="border: 1px solid black; border-radius: 50%; padding: 2px;"> </span>	<b>PC Configuration RUN Mode (Option A)</b> The transmitter is configured via PC and is in normal operating conditions.
LD1 <span style="border: 1px solid black; border-radius: 50%; padding: 2px;">G</span> LD2 <span style="border: 1px solid black; border-radius: 50%; padding: 2px;"> </span> LD3 <span style="border: 1px solid black; border-radius: 50%; padding: 2px;"> </span>	<b>DIP SW Configuration RUN Mode</b> The transmitter is configured via DIP SW and is in normal operating conditions.
ERROR MODE	
LD1 <span style="border: 1px solid black; border-radius: 50%; padding: 2px;">A</span> LD2 <span style="border: 1px solid black; border-radius: 50%; padding: 2px;">A</span> LD3 <span style="border: 1px solid black; border-radius: 50%; padding: 2px;">A</span>	<b>System Error</b> Indicates the CPU's communication error.
LD1 <span style="border: 1px solid black; border-radius: 50%; padding: 2px;">R</span> LD2 <span style="border: 1px solid black; border-radius: 50%; padding: 2px;">R</span> LD3 <span style="border: 1px solid black; border-radius: 50%; padding: 2px;">R</span>	<b>DIP SW Error</b> DIP SW configuration is inappropriate. Check the DIP SW setting referring to Tables 2 – 11.
LD1 <span style="border: 1px solid black; border-radius: 50%; padding: 2px;">G</span> LD2 <span style="border: 1px solid black; border-radius: 50%; padding: 2px;"> </span> LD3 <span style="border: 1px solid black; border-radius: 50%; padding: 2px;">A</span>	<b>Output Saturated in PC Configuration Mode (Option A)</b> The output is saturated. (approximately below -15% or above +115%)
LD1 <span style="border: 1px solid black; border-radius: 50%; padding: 2px;">G</span> LD2 <span style="border: 1px solid black; border-radius: 50%; padding: 2px;"> </span> LD3 <span style="border: 1px solid black; border-radius: 50%; padding: 2px;">A</span>	<b>Output Saturated in DIP SW Configuration Mode</b> The output is saturated. (approximately below -15% or above +115%)

### M-SYSTEM WARRANTY

M-System warrants such new M-System product which it manufactures to be free from defects in materials and workmanship during the 36-month period following the date that such product was originally purchased if such product has been used under normal operating conditions and properly maintained, M-System's sole liability, and purchaser's exclusive remedies, under this warranty are, at M-System's option, the repair, replacement or refund of the purchase price of any M-System product which is defective under the terms of this warranty. To submit a claim under this warranty, the purchaser must return, at its expense, the defective M-System product to the below address together with a copy of its original sales invoice. THIS IS THE ONLY WARRANTY APPLICABLE TO M-SYSTEM PRODUCT AND IS IN LIEU OF ALL OTHER WARRANTIES, EXPRESS OR IMPLIED, INCLUDING ANY IMPLIED WARRANTIES OF MERCHANTABILITY OR FITNESS FOR A PARTICULAR PURPOSE. M-SYSTEM SHALL HAVE NO LIABILITY FOR CONSEQUENTIAL, INCIDENTAL OR SPECIAL DAMAGES OF ANY KIND WHATSOEVER.

M-System Co., Ltd., 5-2-55, Minamitsumori, Nishinari-ku, Osaka 557-0063 JAPAN, Phone: (06) 6659-8201, Fax: (06) 6659-8510, E-mail: info@m-system.co.jp